

Reo Recliner

Assembly Instructions

KING[®]
L I V I N G

Two people are required for safe assembly.

Opening Boxes

DO NOT use a knife to open the King Living boxes as you may damage your furniture. Peel off the tape, then lift & separate the cardboard flaps to open.

Assemble your furniture by following the steps below.

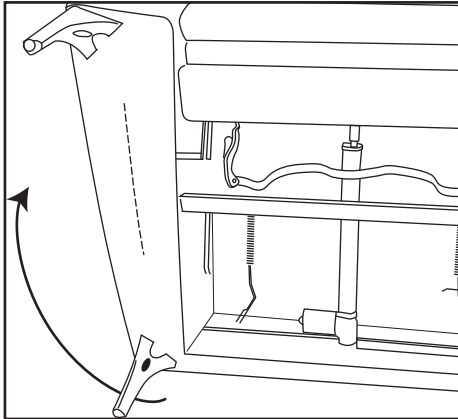

1: Tilt the Reo Module carefully onto its back and insert the Corner Legs all the way into the spigot holes. Legs are in zipped pockets under the Reo.

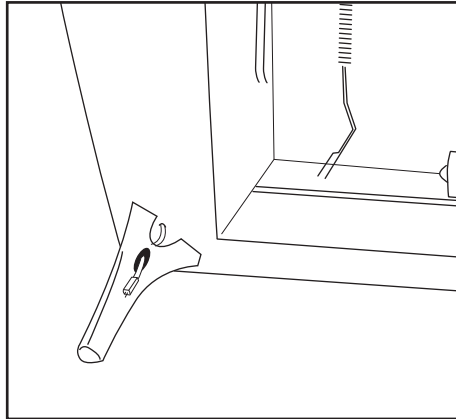

2: Insert the rear power lead into both rear legs – then connect either leg depending on the location of your power supply.

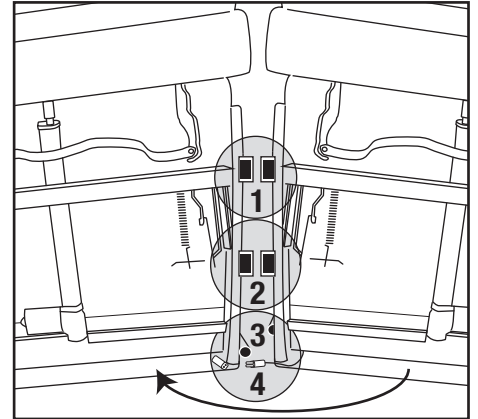

3: Joining modules: Push modules together so that the Support Leg Slots (1-2) and Bolt Tubes (3) line up, and the TouchGlide connectors (4) are close enough to join.

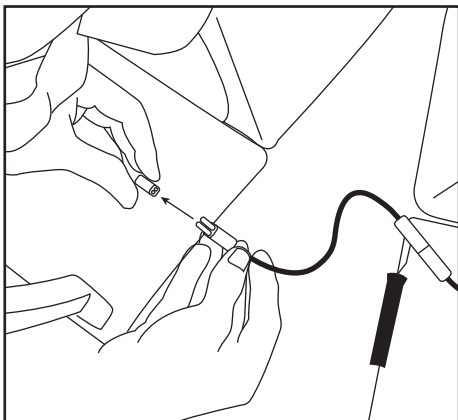

4: Join the male connector (on one module) to the female connector (on the other module).

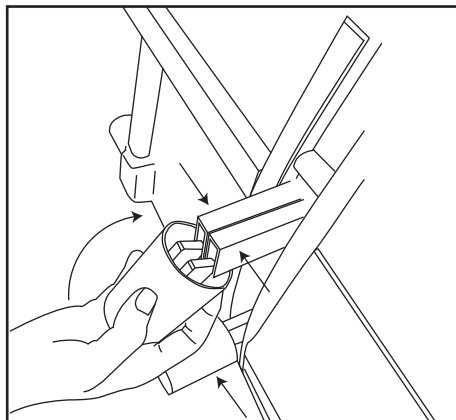

5: Reo Recliners have support legs (except Reo Armchair). Insert the support legs into the receiving holes located near the front and the rear of the module. Support legs help hold modules together.

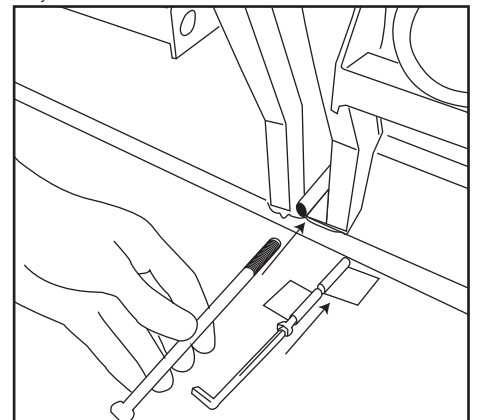

6: Modules need to be bolted together. There are two positions for the bolts. Insert the 1st bolt into the tubes at the lower (rear) end of module. Tighten with the Allen Key.

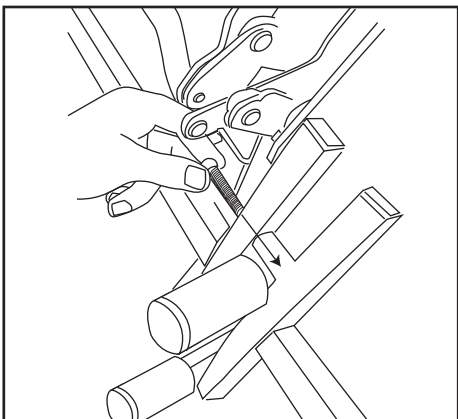

7: Insert the 2nd bolt into the receiving holes at the upper (front) end of module.

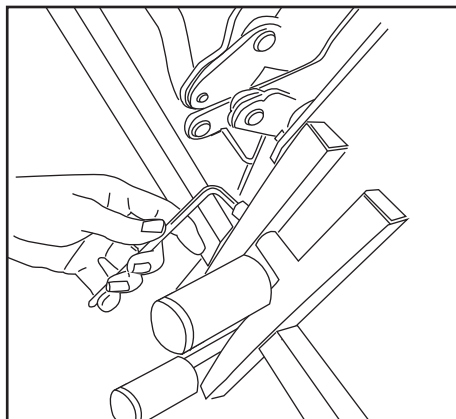

8: Tighten the bolt with the Allen Key.

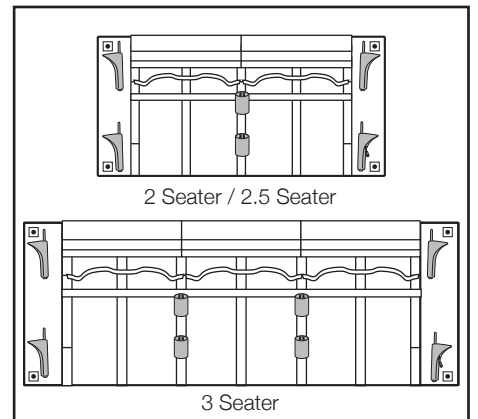

9: The Reo Recliner has now been joined.
2 & 2.5 Seater has 4 corner legs + 2 support legs.
3 Seater has 4 corner legs + 4 support legs.

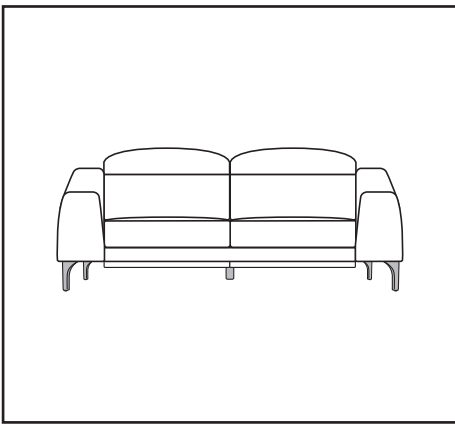

10: 2 Seater / 2.5 Seater: Carefully lower the Reo Recliner back into the upright position after the modules have been correctly joined.

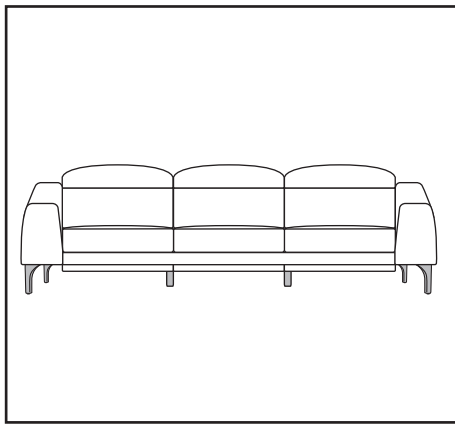

11: 3 Seater: Carefully lower the Reo Recliner back into the upright position after the modules have been correctly joined.

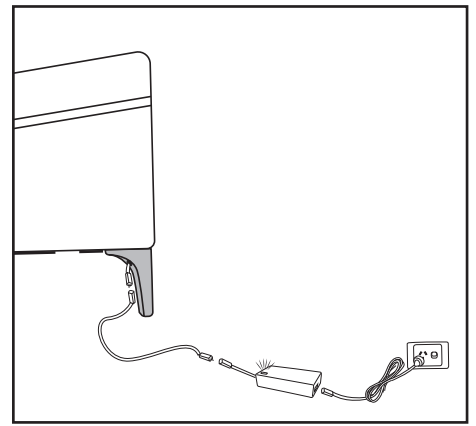

12: When the modules are joined and back in the upright position, join power lead (of either rear leg) to the transformer & connect to your power supply.

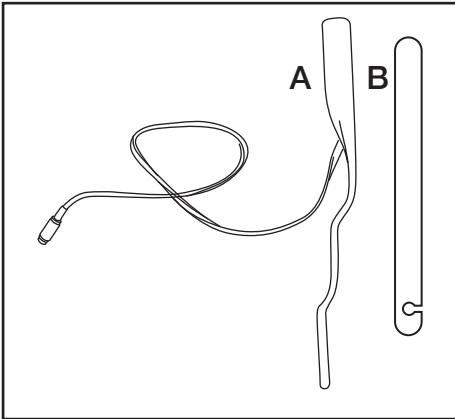

13: Smart Pocket Accessories:
A. SMART Pocket™ Table Bracket (Optional)
B. King Cable Instruction Guide located in Reo's SMART pockets.

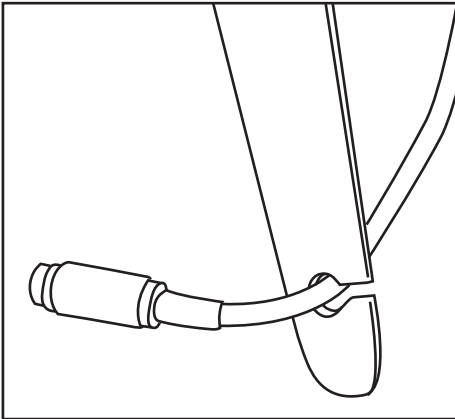

14: Table Bracket Assembly: Insert the end of the Cable into the King Cable Guide as shown.

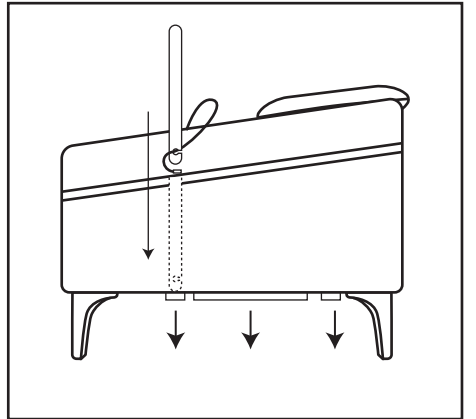

15: Open the Velcro strips underneath the arms and insert the guide and cable into the vertical pocket channel and slide downward.

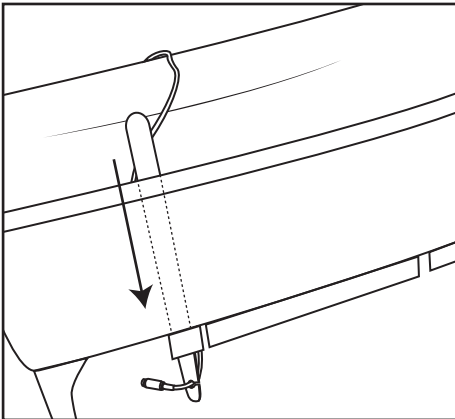

16: Slide the guide & cable all the way down and out through the bottom opening of the pocket channel.

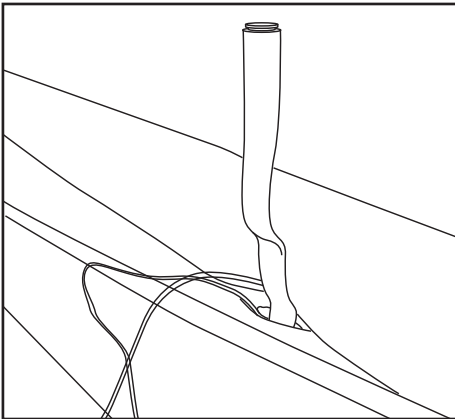

17: Pull any loose cable down (carefully from the bottom) so the cable is concealed within the pocket channel.

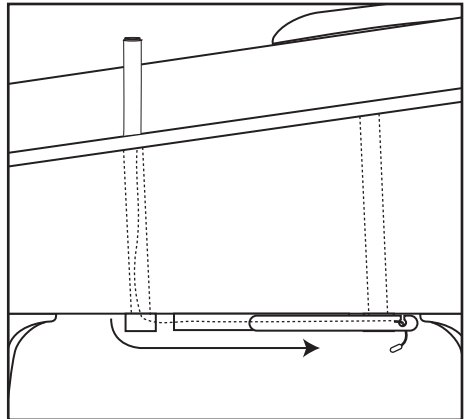

18: Now slide the guide and cable through the horizontal channel towards the back of the Reo all the way through. Remove the Guide.

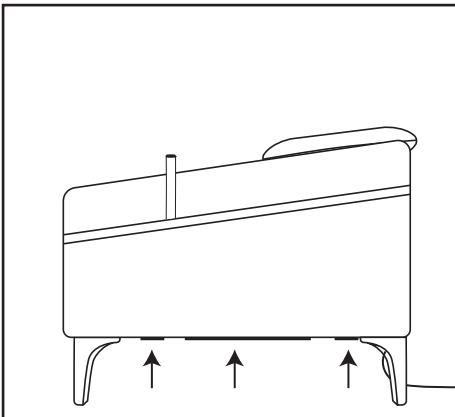

19: Close the Velcro strips to secure & conceal the cable neatly. Table Bracket assembly complete.

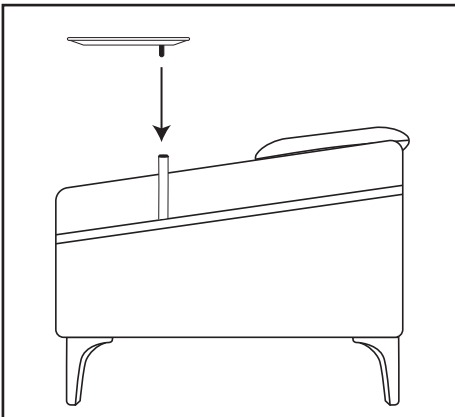

20: SMART Pocket™ Table Assembly: Line up the table connector to the bracket to join together.

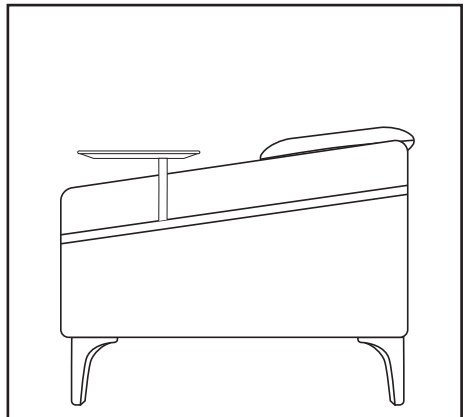

21: Ensure table is securely pushed into the bracket.

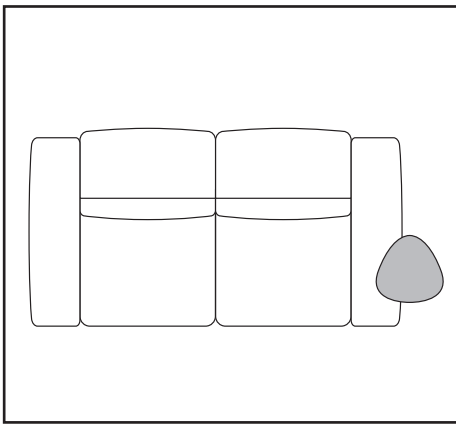

22: SMART Pockket™ Table assembly complete.

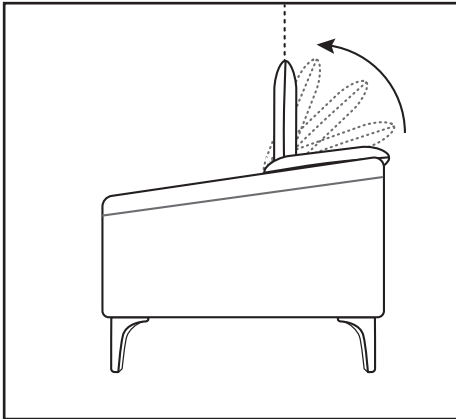

23: The headrest has 15 settings. With headrest in the start position (down) you can lift the headrest up to your desired level. The headrest will click as it enters each new level.

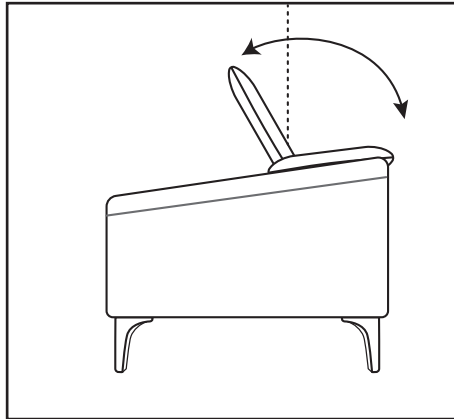

24: To reset headrest to the start position, push headrest past the furthest upright position and then return headrest to the start position (down).

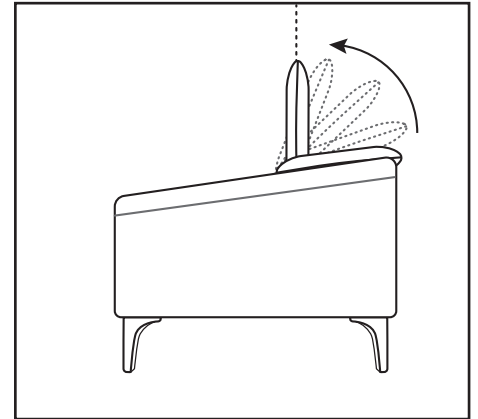

25: With headrest back in the start position (down) you can lift the headrest up to your desired level.

**KING LIVING
CUSTOMER CARE:**

AUSTRALIA:
T 1300 135 464
E service@kingliving.com.au
W kingliving.com.au

NEW ZEALAND:
T 0800 546 422
E service@kingliving.co.nz
W kingliving.co.nz

SINGAPORE:
T +65 6805 4198
E kingcare@kingliving.com.sg
W kingliving.com.sg

MALAYSIA:
T +603 7732 0272
E service@kingliving.my
W kingliving.my

Warning

Important:

Read the below instructions carefully before assembling and using this product.

IMPORTANT: ALWAYS FULLY RETRACT THE FOOTREST BEFORE SITTING IN OR GETTING OUT OF THE RECLINER.

To avoid damage to your recliner, the reclining function should only be operated when you are seated in the recliner. Any open footrests, which have a 15kg weight limit, must be closed before getting out of or into the seat. Sliding forward over the footrest to get out of the seat or getting into a fully reclined seat may cause damage to the mechanism of the recliner and can result in the sofa tipping forward in extreme cases. This built-in tipping point was specifically designed to preserve the integrity of the mechanism if too much pressure is placed on it and to avoid permanent damage. Damage caused by improper use of Recliners will not be covered under Warranty.

- Do not allow children to play with or on the unit or allow children to use the unit unsupervised. Serious injury or death could occur if head or body parts are trapped within or under the unit while it is being operated.
- Ensure children and pets are at a safe distance from the unit when operating the electric mechanism / moving parts.
- Keep hands and feet clear of moving parts at all times.
- Each unit should be operated only by the person sitting on it.
- Only use the electronic mechanism to operate the unit. Do not attempt to open the footrest by pulling on it.
- Always leave the unit in an upright and closed position when not in use to avoid children and pets crawling into any open cavities and becoming trapped under moving parts.
- Always disconnect the electrical cord attached to the unit from power before cleaning or moving the unit or when not in use for an extended period.
- Ensure the unit is clear of walls, furniture and other obstructions that may interfere with a clear path for operation. Ensure that no objects are left under the unit to avoid interference with the internal mechanisms.
- Do not use the unit if it is wet, in water, or around water or any liquid. Keep liquids away from unit. If liquids are spilled on the unit, disconnect from power immediately and wait until the spill is completely dry before reconnecting to power. Do not handle the plug or electric controls with wet hands.
- This product is for indoor residential use only.
- Use only a slightly damp cloth to clean metal parts of the mechanism. Before cleaning ensure the furniture has been disconnected from its power source.
- Ensure electrical wires are free from obstruction and not twisted or trapped. If any wires are damaged, turn off power supply and call King Living Customer Care.
- Do not attempt to disassemble or service the internal mechanism, motor or other parts. No customer serviceable parts inside.

**KING LIVING
CUSTOMER CARE:**

AUSTRALIA:
T 1300 135 464
E service@kingliving.com.au
W kingliving.com.au

NEW ZEALAND:
T 0800 546 422
E service@kingliving.co.nz
W kingliving.co.nz

SINGAPORE:
T +65 6805 4198
E kingcare@kingliving.com.sg
W kingliving.com.sg

MALAYSIA:
T +603 7732 0272
E service@kingliving.my
W kingliving.my